



Bump Steer Correction Tie RodKit - Installation Instructions

Part #2180018, 2180031, 2180033

Cars applicable:

964 - 2180031

993 - 2180018

964 – 2180033 turbo

Parts list:

Quantity	Description
2	Elephant Racing Tie Rod Assembly
2	Steering Rack Bellows Seal
2	Locking Hex Nut, 12mm
2	Flat Washer, #12 X 5mm thick

Introduction –

Bump steer is defined as a change in toe due to the vertical movement of the wheel, such as when driving over a bump. The change in toe causes the car to turn, and the driver needs to correct for this to maintain the intended trajectory. Bump steer becomes even more profound when the car is lowered.

As the name implies, the Elephant Racing bump steer tie rods have been designed to minimize bump steer. Thus, driver corrections are minimized, making driving fast easier. The Elephant Racing bump steer tie rods also eliminate the rubber isolator found in the factory tie rods, thus providing a more direct and responsive steering feel.

Compared with stock tie rods, Elephant Racing bump steer tie rods position the center of the ball stud pivot closer to the steering knuckle. The angle of the tie rod is thus altered, thus changing the position on the bump steer curve.

Elephant Racing tie rods have an angled head to compensate for the changed angle of the tie rod when the car is lowered. At static height, this positions the ball joint stud in the center of its range of motion, thus preventing damage caused by reaching the limits of ball joint travel.

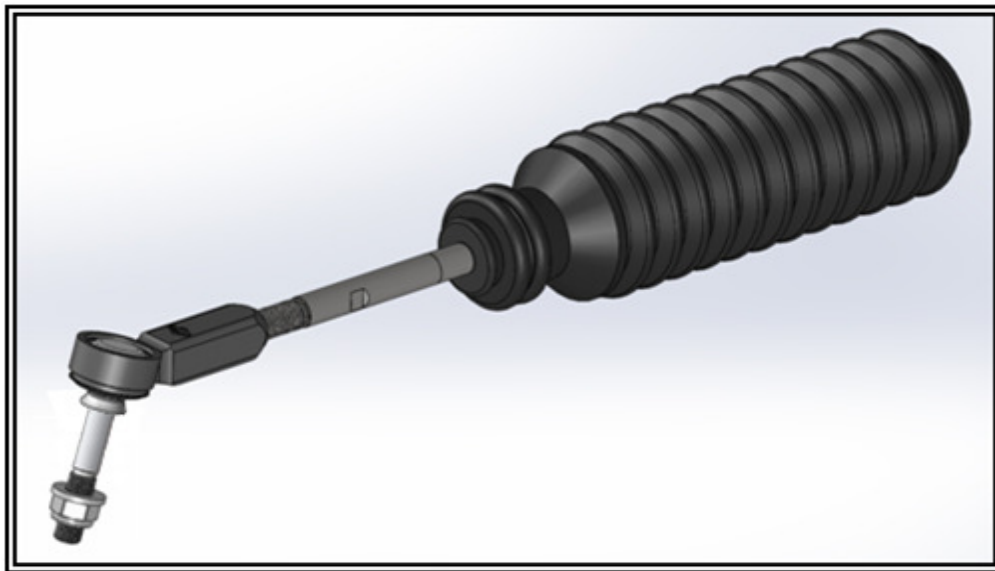

964 / 993 Tie Rod Assembly



Step-by-Step Installation -

1 – Install tie rods

Installation is performed the same as for stock tie rods with the following exceptions.

- Used supplied thick washer & lock nut to secure rod end.

Torque to factory recommended values.

2 – Align Toe

Following Installation, the vehicle toe should be aligned by a trained professional